

DN65 TO DN100
MAINLINE ONLY

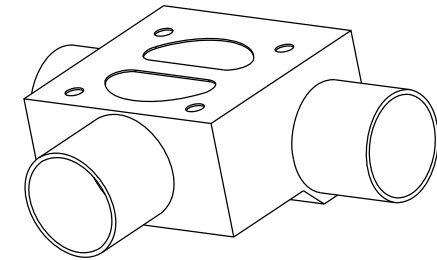

DN50 MAINLINE ONLY

The information on this sheet is Private and Confidential and is the property of Crane Process Flow Technologies Limited and must not be published directly or indirectly in any manner whatsoever without the written permission of the Company and must not be used in any way detrimental to their interests.
© Crane Process Flow Technologies

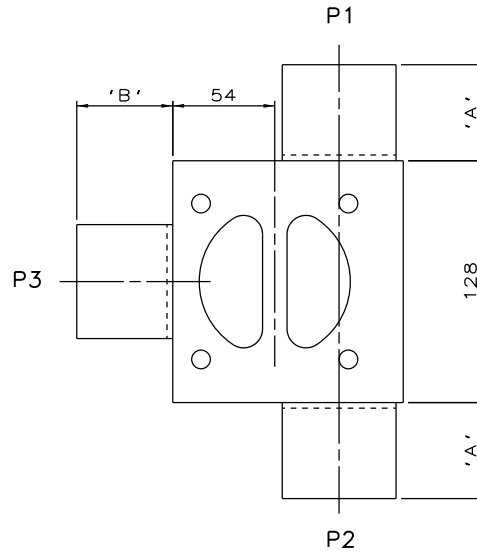
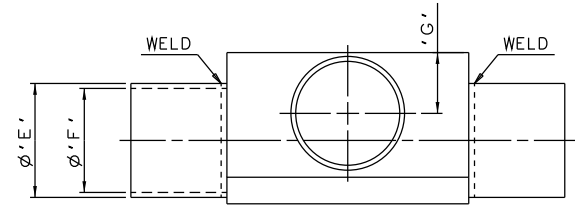
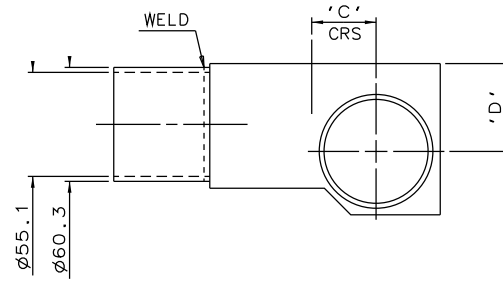

Process Flow Technologies
A Crane Co. Company



Title
SCHEDULE OF LEADING DIMENSIONS FOR DN50 WEIR
'T' BODY WITH ISO 1127 S1 BUTT WELD ENDS

Drawn JRD	Date 14.10.11	UNCONTROLLED IN HARD COPY FORMAT	
Checked RND	Date 23.03.12		
First Angle Projection Method E	DO NOT SCALE	Drawing No. WEB-078	Issue. 2

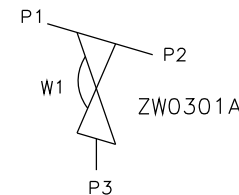

ORIENTATION AS PER
P&ID DIAGRAM FOR
OPTIMUM DRAINABILITY.

MAINLINE SIZE	A	B	C	D	øE	øF	G	BODY WEIGHT
mm	mm	mm	mm	mm	mm	mm	mm	Kgs
DN50	50.8	50.8	34.1	46.5	60.3	55.1	32.2	5.7
DN65	50.8	50.8	42.0	55.0	76.1	70.9	32.2	5.8
DN80	50.8	50.8	48.4	60.0	88.9	83.7	32.2	6.0
DN100	101.6	50.8	61.1	70.0	114.3	109.1	32.2	7.8

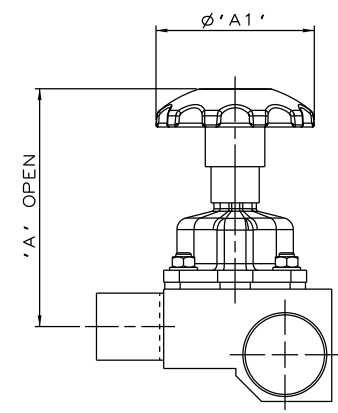

SS NON SEALED
BONNET ASSEMBLY

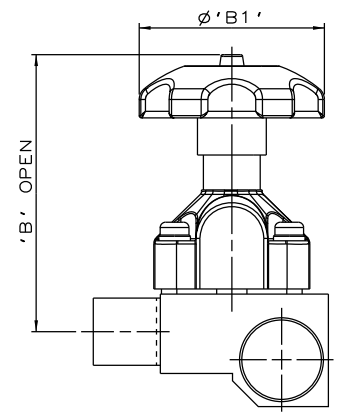

PES BONNET
ASSEMBLY

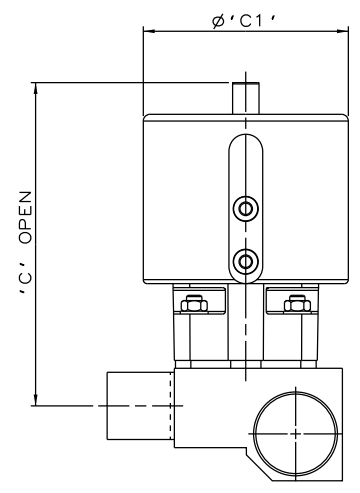

EC ACTUATOR
(ALL MODES)

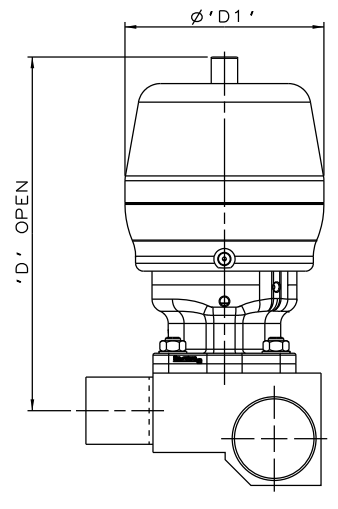

*S360 ACTUATOR

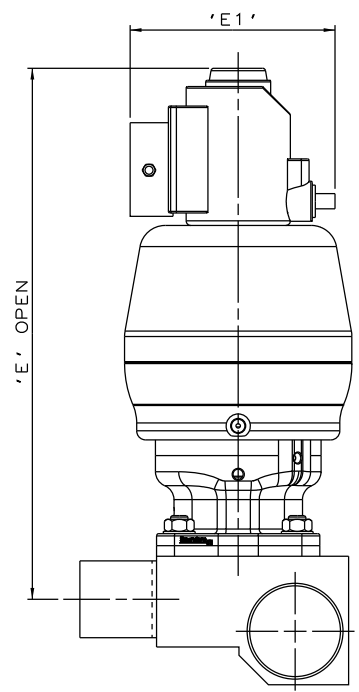

*S360 ACTUATOR
WITH I-VUE SENSOR

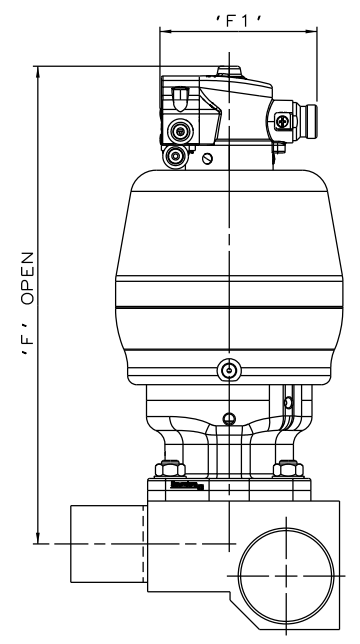

*S360 ACTUATOR
WITH M-VUE SENSOR

The information on this sheet is Private and Confidential and is the property of Crane Process Flow Technologies Limited and must not be published directly or indirectly in any manner whatsoever without the written permission of the Company and must not be used in any way detrimental to their interests.
© Crane Process Flow Technologies

CRANE	Process Flow Technologies A Crane Co. Company	Saunders The Science Inside
--------------	--	---------------------------------------

Title
SCHEDULE OF LEADING DIMENSIONS FOR DN50/2.00 WEIR 'T' BODY WITH BUTT WELD ISO 1127 S1 ENDS. FITTED WITH TOPWORKS OPTIONS

Drawn JRD	Date 15.09.16	UNCONTROLLED IN HARD COPY FORMAT
Checked RND	Date 15.09.16	

First Angle Projection Method E	DO NOT SCALE	Drawing No. WEB-078-ASSY	Issue. 1
---------------------------------	--------------	-----------------------------	-------------

*DIMENSIONS SHOW MAXIMUM ENVELOPE FOR ALL MODES

BRANCH SIZE	A		A1		B		B1		C		C1		D		D1		E		E1		F		F1		
mm	inch	mm	inch	mm	inch	mm	inch	mm	inch	mm	inch	mm	inch	mm	inch	mm	inch	mm	inch	mm	inch	mm	inch	mm	inch
DN50	2.00	184.2	7.25	120.0	4.72	213.2	8.39	140.0	5.51	248.2	9.77	155.0	6.10	271.2	10.68	150.0	5.92	355.2	13.98	136.0	5.35	319.2	12.57	103.8	4.09